



No. 139 Pacific Industrial,
Zengcheng, Guangzhou

+86 20 85163633

www.yuhuaplayingcards.com

lee@yuhuaplayingcard.com



DESIGNER GUIDE BOOK

Introduction

By opening this guidebook, you are taking a significant step toward bringing your game ideas to life. YUHUA is here to support your creativity and talent with comprehensive guidance on manufacturing procedures, artwork design, and illustration creation.

Our goal is to help you navigate the design verification process and get your game into production swiftly and smoothly. With years of expertise in the card game industry, YUHUA offers a complete solution from design to production. We look forward to partnering with you as you bring your creative vision to life and produce exceptional card games!

General Information

- Use CMYK color mode.
- Ensure image resolution is no less than 300dpi.
- Label and organize files by part numbers and names according to the spec sheet.
- Embed all texts and fonts.
- Use vector illustrations for die cuts and place them in different layers.
- Use pure black color settings: C: 0%, M: 0%, Y: 0%, K: 100% and set as over print.
- Keep a 3mm bleed on each side. All artwork and background colors should extend into the bleed area.
- Maintain a 3mm margin area from the artworks to the die-cut lines.
- For box and board: keep a 3mm bleed plus a 15mm wrap to ensure they can be wrapped around the edges.

Please contact your account manager at YUHUA to get templates for your custom card game !

Special Effect/Treatment

In addition to the standard finishes of varnish, UV coating, and lamination, there are several special treatments you can consider for your games. These unique treatments can enhance the overall texture and visual appeal of your game, making it more captivating. We offer a variety of special finish options to help you create a truly distinctive game product.

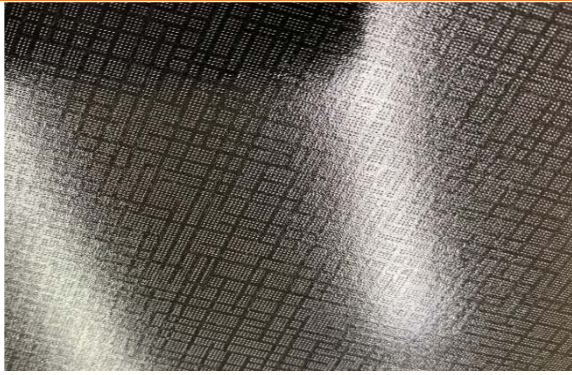

Linen Texture

As a highly popular option, linen finish enhances the attractiveness and tactile experience of your game elements. It is commonly used on boxes, cards, playmats, and punchboards.

****Note:** Linen texture does not work well with dry erase markers, as the marker residue will get caught in the texture.

Foil Stamping

By using this process, you can add a gold or silver coating to the printed sheet to emphasize specific elements. Unlike Spot UV, foil stamping can also be applied to glossy surfaces. The file requirements are the same: create the design as a vector, and place it in different layers using a solid color.

****Note:** Color of foil stamping is optional, please contact us for more details.



Spot UV

With this process, you can create a special shiny or glossy area on any matte surface, typically used to emphasize elements such as logos or text. Design the Spot UV in vectors and place it in a separate layer using a solid color.

Embossing/Debossing

This process adds varying depths to your illustrations on paper, commonly applied to boxes or tuck boxes. Design the embossing area in vectors and place it in a separate layer using a solid color.





Edge Gilding/Printing

Edge gilding or printing adds a luxurious touch to your game components by applying a metallic or colored finish to the edges of cards or pages. This process enhances the visual appeal and uniqueness of your product. Consult us for available color options and design requirements.

REMINDER: To minimize production tolerance, please ensure the mask area for finishing is at least 1% larger than the original illustration.

All About Cards

The table below lists common sizes for card games. You can choose the most suitable one for your game, or [contact us to customize your own size.](#)

Rectangel		Square		Circle
63x88mm	87x126mm	51x51mm	70x70mm	55mm
57x87mm	32x44mm	63.5x63.5mm	80x80mm	45mm
44.5x63.5mm	50x75mm	67x67mm	89x89mm	

Bleed and margin: All cards must have 3mm of bleed and 3mm of margin. Please extend the background artwork to the bleed line or beyond, and keep important artwork and all text inside the margin line.

File format: When submitting cards, you should create a single, multi-page PDF where each page contains a single card front. Do not create individual PDF files for each card. If your deck has a single card back, add that card back as the last page of the file. If you have several different card backs, upload one file for all the card fronts and a second file for all the card backs.

Example 1: Deck A has 54 cards with a single back. The PDF for Deck A will be 55 pages long, with the 55th page being the card back.

Example 2: Deck B has 54 cards with multiple backs. There will be two PDFs for Deck B: one with the 54 card fronts, and a second file with the 54 card backs in the same order. It helps to be descriptive when you name your file.

Border black: For a deep, consistent black that makes it easier to color match between print runs and expansions, consider using this color formula: (C:40% M:0% Y:0% K:100%).

- Bleed Line
- Die Line
- Safe Line

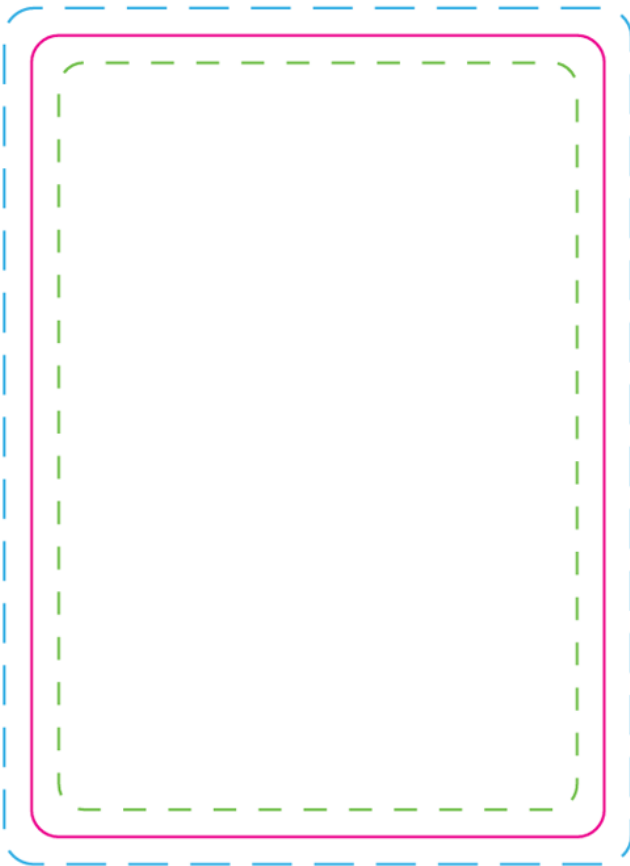

R4

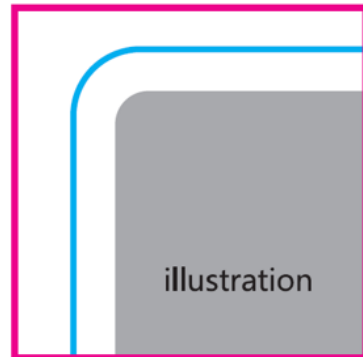

R2.5

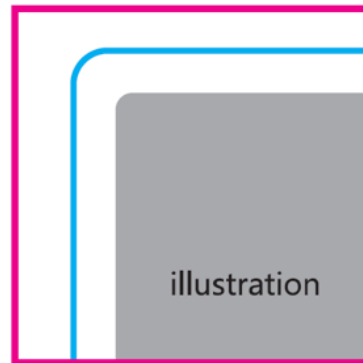

We provide regular rounded corners with 4mm, 3.5mm, 3mm, 2.5mm radius as an option to fit your design. Contact us to make a better decision.

Card Stock

YUHUA provides different kinds of cardstocks with different price ranges for option.

1, Cost effective option – Smooth or linen Blue Core Cardstock (280/300gsm), For customers with lower budgets and smaller volume requirements, or those targeting game design, advertising promotions, wedding giveaways, and similar purposes.

2, Superior quality option – Smooth or linen Black Core Cardstock (300/310/330gsm), It is ideal for scenarios where durability and anti-cheating measures are crucial, such as casinos, magic performances, high-end gifts, and premium games.

3, Art paper option – White art board (300/350/400gsm), It is made of ordinary white cardstock coated with a white chemical layer, providing a smooth surface, high whiteness, and excellent ink absorption. This material is ideal for game cards, tarot cards, oracle cards, and study cards that require a steady hand. However, it is not suitable for casino cards.

4, High quality PVC material – White/Black (0.3, 0.32, 0.35mm) with texture options of smooth, fine sand and coarse sand. This cardstock is offering excellent water resistance, flexibility, and maintaining its shape, color, and mobility even after exposure, wetting, and heavy use. It is the top choice for poker and game card players, providing a silky smooth operating experience.

5, Holographic Paper Material – with a weight range from 85 to 475gsm, marketable color or customized. This effect creates a three-dimensional appearance and shifts colors when viewed from different angles, giving it a visually striking and dynamic look.

Booklet & Paper Sheets

There are 4 major book binding type: Saddle Stitch, Perfect Bound, Hard Cover and Spiral/Wire Book. Contact us for more details and figure out the most cost-effective page numbers for your booklets.

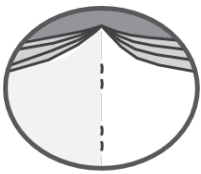

Saddle Stitch

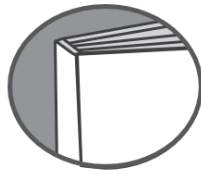

Perfect Bound

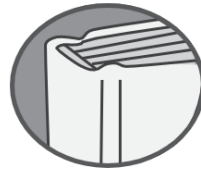

Hard Cover

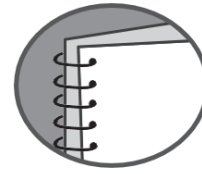

Spiral/Wire Book

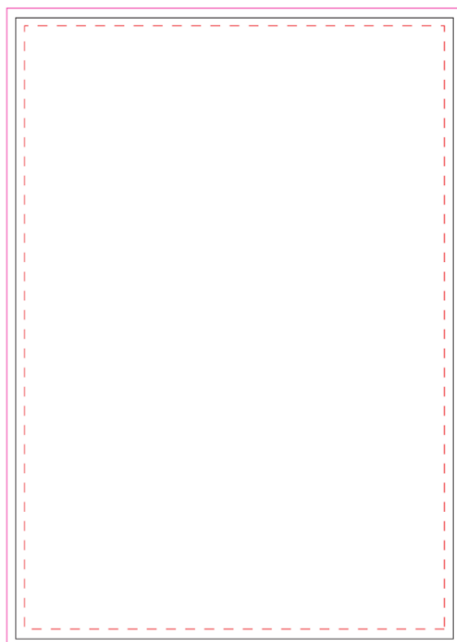

_____ Bleed

3mm bleed area is required around the cut line.

_____ Die Cut

This is how the print sheet will be trimmed. Die-cut lines must be on separate layers and hidden when outputting the file.

----- Margin

Keep all important text and illustrations within the margin area (3mm away from the die-cut line) to avoid trimming. Increase the margin to 6mm for documents with more than 32 pages.

Bleed and Margin Requirements:

- All rulebook and paper sheet files must include a 3mm bleed.
- Margin sizes for rulebooks vary based on the number of pages:
 - 1-28 pages: Use a standard 3mm margin.
 - 32-64 pages: Increase the margin to 5mm.
 - 68+ pages: Contact us for templates and alternative binding methods.

Page Count:

- Saddle-stitched rulebooks must have a total page count that is a multiple of four. Rule sheets can be single or double-sided.

File Setup:

- Submit rulebooks as multi-page PDFs with each page of the booklet as a separate page in the PDF. Do not use two-page spreads. Our production team will format the booklet for print with the correct pagination.

Game Board

The game board is a primary component of your game. To save on packaging costs, the board will be folded into 1/2, 1/4, or 1/6 of its size to fit inside a smaller box. Please refer to the following illustrations for a better understanding.

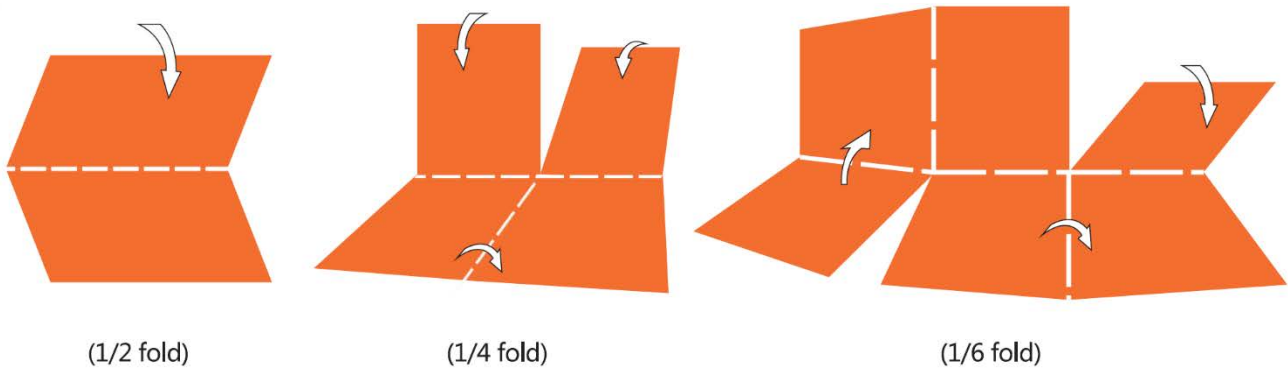

Double sided

Printing a custom back for your game board adds minimal cost and can significantly enhance your game. If you are designing a double-sided game board, please note that the back side needs to be 3mm smaller on all sides than the front. This is because we mount the back sheet on top of the wrapped edges from the front side of the game board. Don't forget to include the standard 3mm bleed!

For example, if your game board is 200mm x 400mm, the trimmed size for the back will measure 194mm x 394mm. However, the file dimensions should still be 200mm x 400mm to include the bleed.

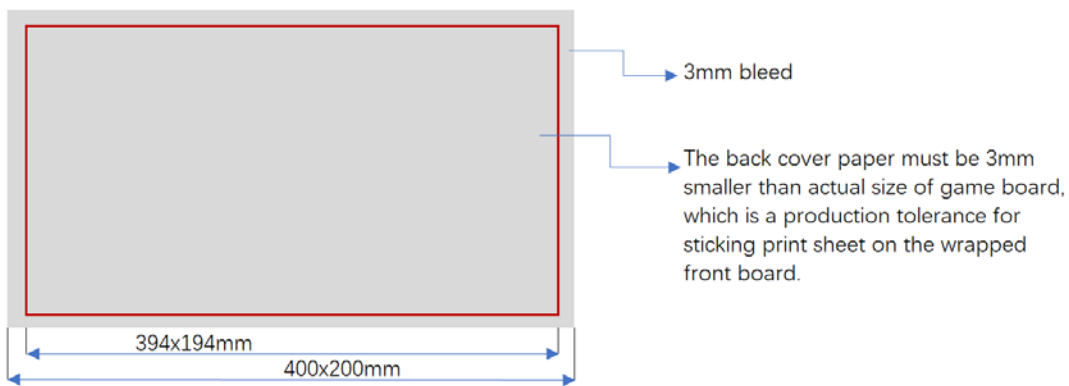
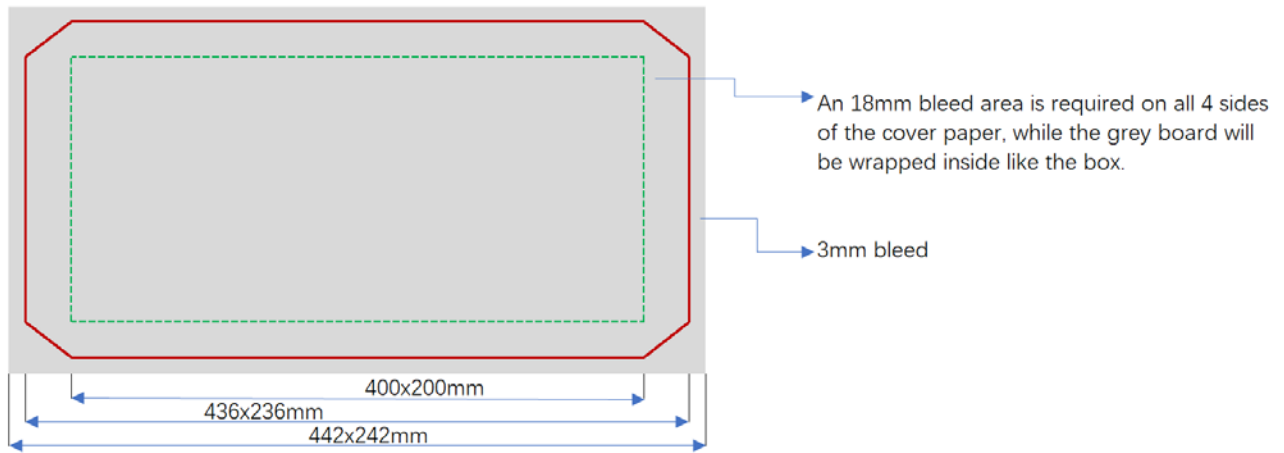

REMINDER: Keep all important texts and illustrations inside the margin area (3mm away from the folding line) to avoid an o them be trimmed. And you can decide your game board to be wrapped with printed paper or black paper, it will be presumed to be wrapped with black paper if you do not specify.

Packaging Options

Here are the four most popular box styles for your card games. Additionally, we offer a variety of packaging options including [plastic boxes](#), [tin boxes](#), [corrugated boxes](#), [foil pack](#) or [custom box styles](#) to suit your design. Explore our packaging solutions to find the perfect fit for your needs.



TUCK BOX



MAGENETIC BOX

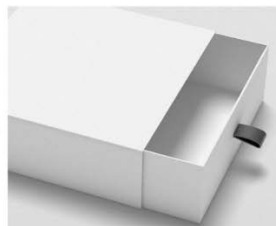

DRAWER BOX



LID AND BOTTOM BOX

Tuck Box

If your game consists solely of cards or requires a smaller box within the main game box to hold pieces or components, a lightweight, one-piece tuck box is an excellent storage solution.

Bleed and margin: All tuck box files must have the standard 3mm of bleed and margin.

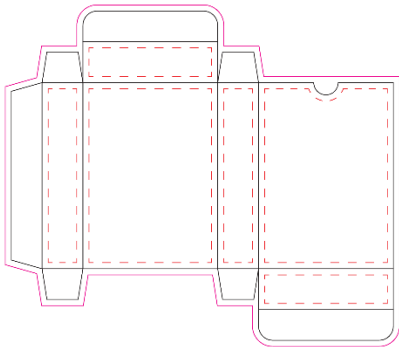

Lid and Bottom Box

This box format is also known as a two-piece or two-part box. We will provide a box template according to your specifications, allowing you to easily apply your artwork to the corresponding panels.

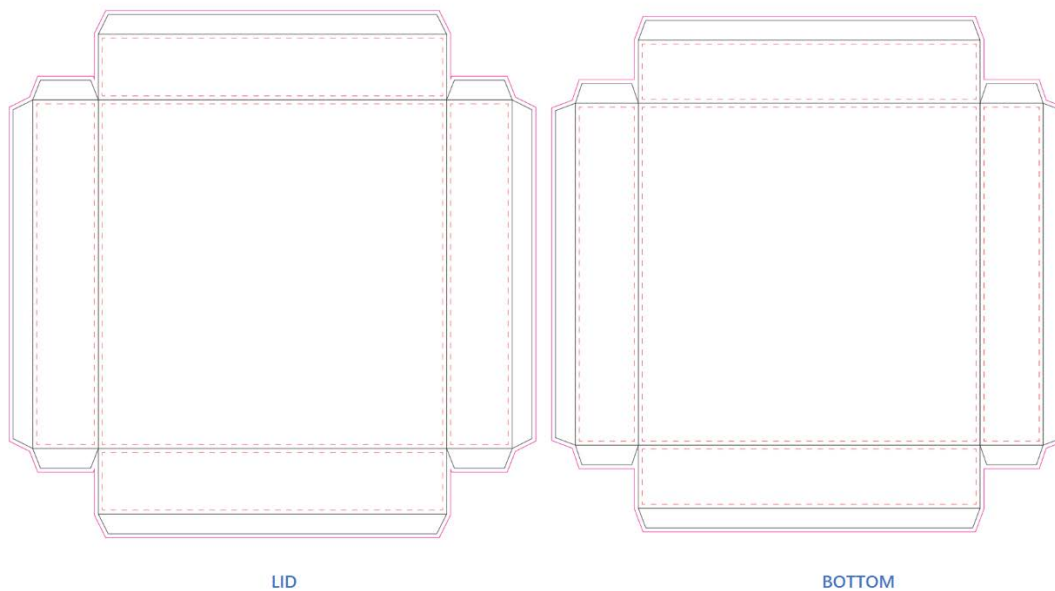

Bleed: An 18mm bleed area is required on each side of the box, as the flaps will be wrapped inside the box.

Margin: Keep all important text and illustrations within the margin area (3mm away from the die cut line and folding line) to avoid them being trimmed.

Die Cut: Die cut lines must be on separate layers and hidden when outputting the file.

Legal Markings and Information

When designing your game box, be sure to consider necessary markings and labels. Some are legally required, while others are optional but recommended for the benefit of potential buyers and retailers.

UPC/EAN Code -

This unique identification code is used for a single product worldwide. You can contact a barcode company to purchase and generate a barcode number.

MADE IN CHINA

Country of Origin -

For example, "Made in China." This must be displayed on the box to pass through customs.

Age Graphic Symbol -



This is mandatory and must have a diameter of no less than 10mm, indicating that the game is not suitable for children under 3 years old.

Importer Information -

If you are the importer of your game, you need to include detailed information about your company on the box. This usually includes the company name, address, and telephone number.

Small Part Warning -

The following text must be displayed on the box according to safety testing directives, as most games are not designed for infants and may contain small parts or small balls. "WARNING: CHOKING HAZARD — Small parts. Not suitable for children under 36 months."

CE mark -

The CE mark must be displayed on the box with a minimum height of 5mm for any products sold in Europe. This mark declares that the product complies with the EU directive. If an EU customer requires a test report, you will need to send the product to a third-party laboratory for EN71-1/2/3 testing.



Glossary of Key Terms

Black Border:

Black border refers to the CMYK color recommended for black borders on cards. This specific shade ensures consistency and easier color matching across different print runs. The color formula for this black border is: C: 40%, M: 0%, Y: 0%, K: 100%.

Pure Black:

Pure black is the CMYK color used for black text, icons, and UPC symbols. It ensures sharp, clear printing of these elements. The color formula for pure black is: C: 0%, M: 0%, Y: 0%, K: 100%.

Rich Black:

Rich black, which can be any CMYK combination that appears black, should be avoided for text, small icons, and UPC labels to prevent issues with clarity and legibility.

Bleed:

Bleed is the extended area of a design that goes beyond the trim/cut line. This extra area is printed and then cut off to ensure there are no unprinted edges in the final product.

CMYK Color:

The CMYK color model (Cyan, Magenta, Yellow, and black) is used in color printing. It is a subtractive model, meaning it subtracts light to create colors. This model is fundamental in the printing process.

RGB Color:

The RGB color model (Red, Green, Blue) is an additive model used primarily for digital displays. Colors in RGB are created by adding light. It's important to note that not all RGB colors can be reproduced in CMYK, so RGB should not be used in files meant for printing.

PPI (Pixels Per Inch):

PPI measures the resolution of an image, indicating the amount of visual data in a graphic. Higher PPI means higher resolution. All images for printing should be at least 300 PPI to meet industry standards.

Die lines:

A die line is a vector graphic that guides machinists in creating punch-outs for die-cutting. Designers use die lines to correctly layout documents that will be die-cut.

Margin (Inner Bleed or Safe Zone):

The margin is the space between the trim/cut line and the main content/art area of a design. This area prevents important elements from being cut off and helps maintain the visual integrity of the design.

Overprint:

Overprinting is the technique of printing one color over another to achieve crisp text and avoid misalignment issues. It ensures precise and clear printed text and images.

Raster Graphics:

Raster graphics are images made up of individual pixels. While these can be resized smaller without issue, enlarging them can cause blurriness or pixelation. Adobe Photoshop is commonly used to create raster graphics.

Trim Size:

Trim size refers to the final dimensions of a printed component after the bleed area has been cut off. It is the intended size of the final product.

Vector Graphics:

Vector graphics use mathematical equations to define shapes, allowing them to be resized infinitely without losing quality. These graphics are created and edited using Bézier curves. Adobe Illustrator is a popular tool for generating vector graphics.